



Series TT05 universal torque testers can be used for a range of applications up to 100 lbFin [11.5 Nm]. The stainless steel loading surface features a matrix of threaded holes, ideal for accommodating specialized fixtures and attachments. The testers' rugged design and simple, intuitive operation allow for use in laboratory and production environments.

Accuracy of $\pm 0.3\%$ and blazingly fast sampling rate of 7,000 Hz ensure reliable and consistent test results, even in quick-action applications. Password protection is provided to prevent unauthorized changes to settings and calibration.

The TT05 includes a range of sophisticated productivity-enhancing features, including USB, RS-232, Mitutoyo, and analog outputs, automatic data output and zeroing upon sample break, memory storage for 1,000 readings, pass/fail indicators and outputs, and more. First / second peak torque detection is useful for torque tool testing, tamper evident closure testing, and other applications.

Series TT05 testers include MESUR™ Lite data acquisition software. MESUR™ Lite tabulates continuous or single point data. Data stored in the TT05's memory can also be downloaded in bulk. One-click export to Excel allows for further data manipulation.

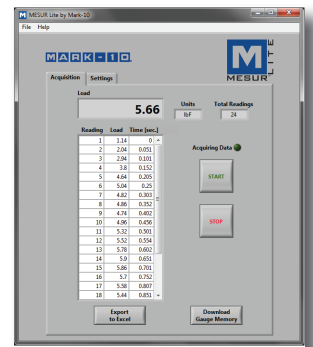

MESUR™ Lite data acquisition software is included with Series TT05 testers

Features

- Stainless steel loading plate with threaded holes accommodates fixtures and attachments
- USB, RS-232, Mitutoyo, and analog outputs
- Automatic output, data storage, and zeroing upon sample break helps automate testing processes
- First / second peak detection for torque tool testing, bottle cap testing, and other applications
- 1,000-point data memory with statistics and outputs
- Password protection prevents unauthorized changes
- High-speed 7,000 Hz sampling rate accurately captures peak torque values
- Programmable set point indicators and outputs for pass/fail determination
- MESUR™ Lite data collection software included

Controls & Indicators

- Set points
- Current / peak reading
- Pass / fail indicators
- Battery indicator
- Memory storage for 1000 readings
- Access the tester's settings menu via an easy-to-use interface
- One-push data output to a PC, printer, or other device (auto-output also possible)

- Clockwise/counter-clockwise indicator
- Peak readings
- Measurement mode
- Units of measurement
- Analog load bar w/set point markers
- Zero the reading to begin a new test (auto-zero also possible)
- Toggle between real time and peak display modes



Distribué par Wimesure

54, rue de Versailles • 78460 CHEVREUSE • Tél. 01 30 47 22 00 • Fax 01 30 47 28 29
 www.wimesure.fr • info@wimesure.fr

Optional Items



CT002 Carrying case
Provides storage space for the TT05 tester, gripping jaws, AC adapter, and accessories.

Dimensions in [mm]

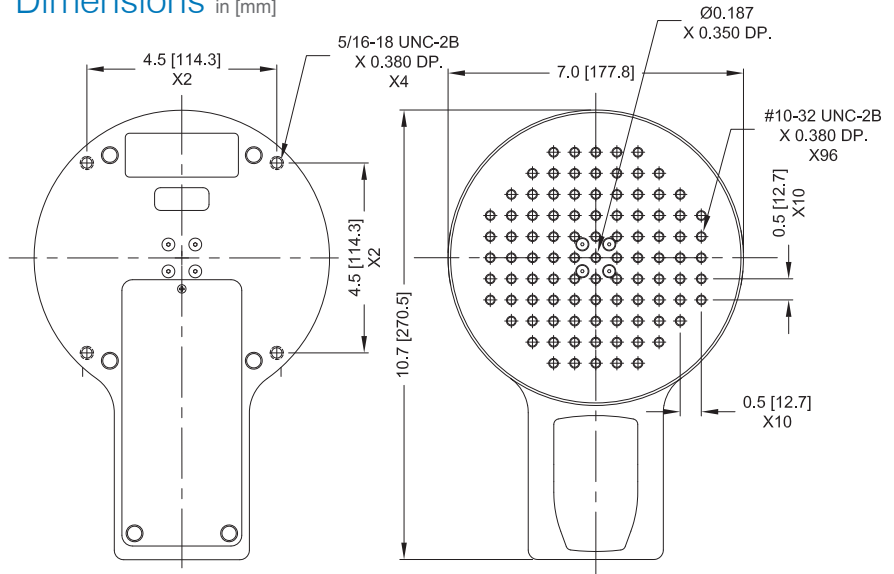

Specifications

Accuracy:	±0.3% of full scale
Sampling Rate:	7,000 Hz
Power:	AC or rechargeable battery. Multi-step low battery indicator is displayed, tester shuts off automatically when power is too low.
Battery life:	Backlight on: up to 7 hours of continuous use Backlight off: up to 24 hours of continuous use
Units:	ozFin, lbFin, lbFft, Nm, Ncm
Outputs:	USB / RS-232: Configurable up to 115,200 baud. Mitutoyo: Serial BCD suitable for all Mitutoyo SPC-compatible devices. Analog: ±1 VCD, ±0.25% of full scale at capacity. General purpose: Three open drain outputs, one input. Set points: Three open drain lines.
Safe overload:	150% of full scale (display shows "OVER" at 110% and above)
Weight:	10.9 lb [4.9 kg]
Included items:	Universal voltage AC adapter, battery, quick-start guide, USB cable, resource CD (USB driver, MESUR™ Lite software, MESUR™ gauge DEMO software, and user's guide), and NIST-traceable certificate of calibration (certificate with data is available for an additional charge).
Environmental requirements:	40 - 100°F, max. 96% humidity, non-condensating
Warranty:	3 years (see individual statement for further details)

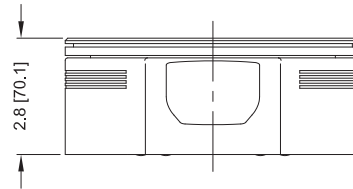

Capacity x Resolution

Model No.	lbFin	ozFin	lbFft	Ncm	Nm
MTT05-12	12 x 0.005	192 x 0.1	1 x 0.0005	135 x 0.1	1.35 x 0.001
MTT05-25	25 x 0.01	400 x 0.2	2 x 0.001	290 x 0.2	2.9 x 0.002
MTT05-50	50 x 0.02	800 x 0.5	4 x 0.002	570 x 0.5	5.7 x 0.005
MTT05-100	100 x 0.05	1600 x 1	8 x 0.005	1150 x 0.5	11.5 x 0.005

All models include 110V AC adapters. Add suffix 'E' for euro plug (220V), 'U' for UK plug (220V), or 'A' for Australian plug (220V).

Ex: MTT05-12E, MTT05-25U, MTT05-50A



Distribué par Wimesure

54, rue de Versailles • 78460 CHEVREUSE • Tél. 01 30 47 22 00 • Fax 01 30 47 28 29
www.wimesure.fr • info@wimesure.fr