



The MGT Torque Gauge is an economical solution for most basic torque measurement applications. A dedicated remote torque sensor with a Jacobs chuck can be used to grip a sample, bit, or fixture. The gauge's rugged reversible aluminum housing allows for hand-held use or test stand mounting. Three pushbuttons allow the user to easily select units of measurement, reset zero, and recall clockwise and counterclockwise peak torque values. The MGT is compatible with Mark-10 torque test stands, and is available in capacities from 10 ozFin to 100 lbFin.

Specifications

Accuracy:	±0.5% of full scale ±1 digit
Power:	AC or non-rechargeable battery, with Intelligent Power Management System (IPM). IPM warns the user via a "LO BAT" indicator and then will power off the gauge.
Battery life:	30 hours of continuous use
Selectable units of measurement:	lbFin/ozFin, kgFmm, Ncm (depending on model)
Safe overload:	150% of full scale (display shows "----" at 110% and above)
Weight:	1.8 lb [0.8 kg]
Environmental requirements:	40° F - 100°F [5°C - 45°C], <96% humidity (non-condensating)
Thermal effects:	Zero: 0.03% of full scale/°C, Span: 0.01% of full scale/°C
Housing construction:	Aluminum
Warranty	3 years (see individual statement for further details)

Features

Compact design	Portable and flexible in a wide range of applications
Push-button calibration	Simple and quick calibration procedure
Peak memory	For CW and CCW directions
Selectable units of measurement	Measure in lbFin/ozFin, kgFmm, or Ncm (depending on model)

Dimensions

in [mm]

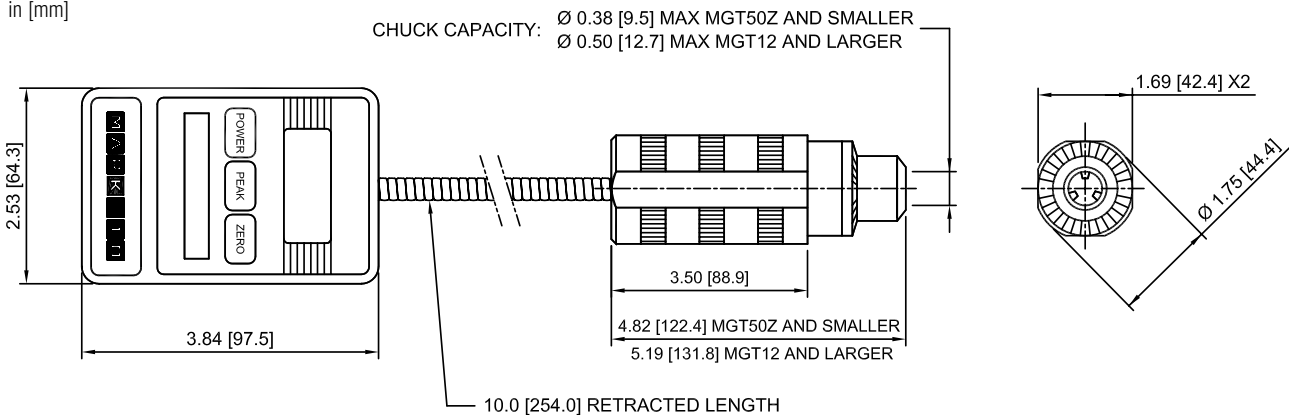

Ordering Information

Model No.	Capacity x Resolution
MGT10Z	10 x 0.01 ozFin, 7 x 0.005 kgFmm, 7 x 0.005 Ncm, 110V
MGT20Z	20 x 0.02 ozFin, 14 x 0.01 kgFmm, 14 x 0.01 Ncm, 110V
MGT50Z	50 x 0.05 ozFin, 36 x 0.05 kgFmm, 35 x 0.05 Ncm, 110V
MGT12	12 x 0.01 lbFin, 140 x 0.1 kgFmm, 135 x 0.1 Ncm, 110V
MGT50	50 x 0.05 lbFin, 580 x 0.5 kgFmm, 570 x 0.5 Ncm, 110V
MGT100	100 x 0.1 lbFin, 1150 x 1 kgFmm, 1150 x 1 Ncm, 110V

For 220V operation, add suffix E to model number. Example: MGT12E



Specifications subject to change without prior notice



Distribué par Wimesure

54, rue de Versailles • 78460 CHEVREUSE • Tél. 01 30 47 22 00 • Fax 01 30 47 28 29
www.wimesure.fr • info@wimesure.fr