

- **Robust design for arduous applications**
- **Return-to-center or return-to-end options**
- **Under-panel depth minimized to 9mm**
- **Rated for 5 million cycles**
- **Hall-effect sensor technology**
- **Dual outputs with sense and voltage span options**
- **IP67 sealing above panel**
- **Color-coded 'Tab' options**
- **Can be supplied as 'base-only' so the colored tabs can be fitted at final installation**



The JC1200 offers the next generation of paddle joystick from Curtiss-Wright to build on the success of the Penny & Giles potentiometric JC120. This new joystick utilizes non-contacting, Hall-effect sensing technology for long-life integrity of the output signal. Operating feel has been an important part of this new development to make this unit as smooth and easy to operate as possible throughout the 5 million cycle life.

Hall-effect sensing eliminates contact wear and provides safety functionality via dual outputs, which can be set to positive or negative ramps, or a combination of both. Electronic robustness is assured with sealing of the internal PCB to a rating of IP65, while a joystick to panel rating of IP67 can be achieved.

A choice of paddle 'Tabs' is available in nine different colors. These can be fitted at the factory or supplied as loose parts to be selected as part of the final installation process.



Return-to-Center



Return-to-End



## CONTENTS

<b>Configuration &amp; Ordering Codes</b> .....	<b>3</b>
Output.....	3
Output Sense .....	4
Spring Return Position .....	5
Paddle Insert Color .....	5
<b>Installation</b> .....	<b>6</b>
Mechanical .....	6
Dimensions - Spring Return to Center .....	6
Dimensions - Spring Return to End .....	7
Panel Mounting Details - Standard .....	8
Panel Mounting Details - Non-Standard .....	9
Electrical Connections.....	10
<b>Specifications</b> .....	<b>11</b>
Electrical .....	11
Mechanical .....	11
EMC .....	12
Environmental .....	12

© 2015 Curtiss-Wright. All rights reserved.

Curtiss-Wright accepts no responsibility for possible errors in catalogs, brochures and other printed material. Curtiss-Wright reserves the right to alter its products without prior notice. This also applies to products already Ordered provided that such alterations can be made without affecting agreed specifications.  
All trademarks in this material are properties of their respective owners.



## CONFIGURATION & ORDERING CODES

JC1200-GEN-X-XX-X-XX

Type	Output	Output Sense	Spring Return Position	Paddle Insert
JC1200-GEN	X	XX	X	XX
	A	PN	C	00
	B	PP	R	01
		NN		02
				03
				04
				05
				06
				07
				08
				09

### OUTPUT

JC1200-GEN-X-XX-X-XX

Code	Description
A	10-90% of 5V supply (0.5-4.5V nominal)
B	20-80% of 5V supply (0.1-4.0V nominal)



### OUTPUT SENSE

JC1200-GEN-X-XX-X-XX

Code	Description
PN	Output 1: Positive slope    Output 2: Negative slope
PP	Output 1: Positive slope    Output 2: Positive slope
NN	Output 1: Negative slope    Output 2: Negative slope

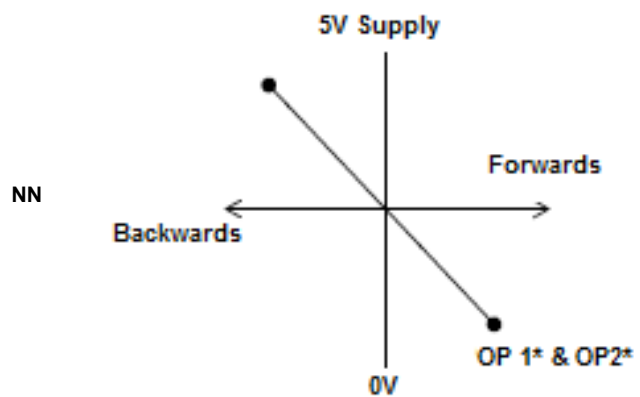
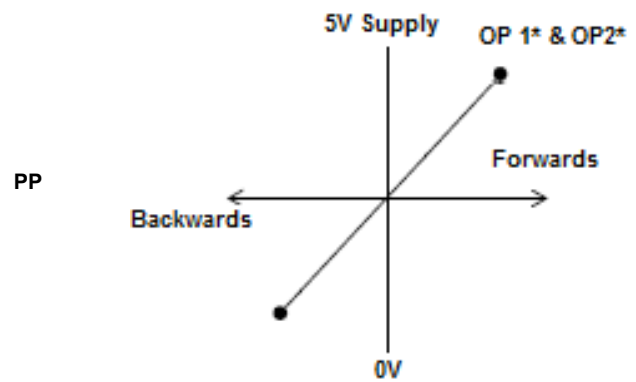
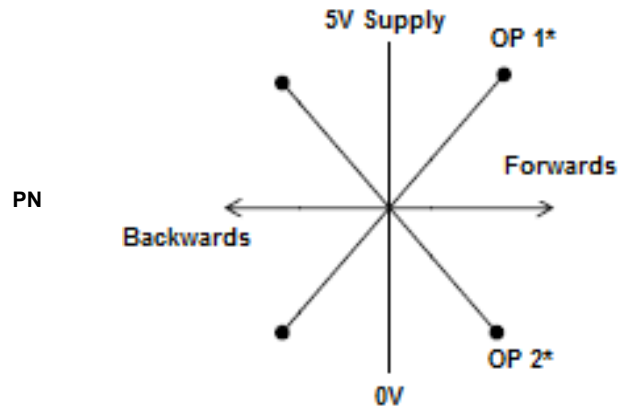









\* 10-90% or 20-80% of 5V supply

**SPRING RETURN POSITION**JC1200-GEN-X-XX-X-XX

Code	Description
C	Center
R	End (Reverse)

**PADDLE INSERT COLOR**JC1200-GEN-X-XX-X-XX

Code	Color Description	Applicable RAL Number	Individual Colored Tab Part Number
00	Colored tab not fitted		
01	 Black	RAL 9005	P318818MK1
02	 Grey	RAL 7042	P318818MK2
03	 White	RAL 9003	P318818MK3
04	 Yellow	RAL 1023	P318818MK4
05	 Orange	RAL 2007	P318818MK5
06	 Red	RAL 3028	P318818MK6
07	 Purple	RAL 4006	P318818MK7
08	 Blue	RAL 5017	P318818MK8
09	 Green	RAL 6038	P318818MK9



## INSTALLATION

### MECHANICAL

#### Dimensions - Spring Return to Center

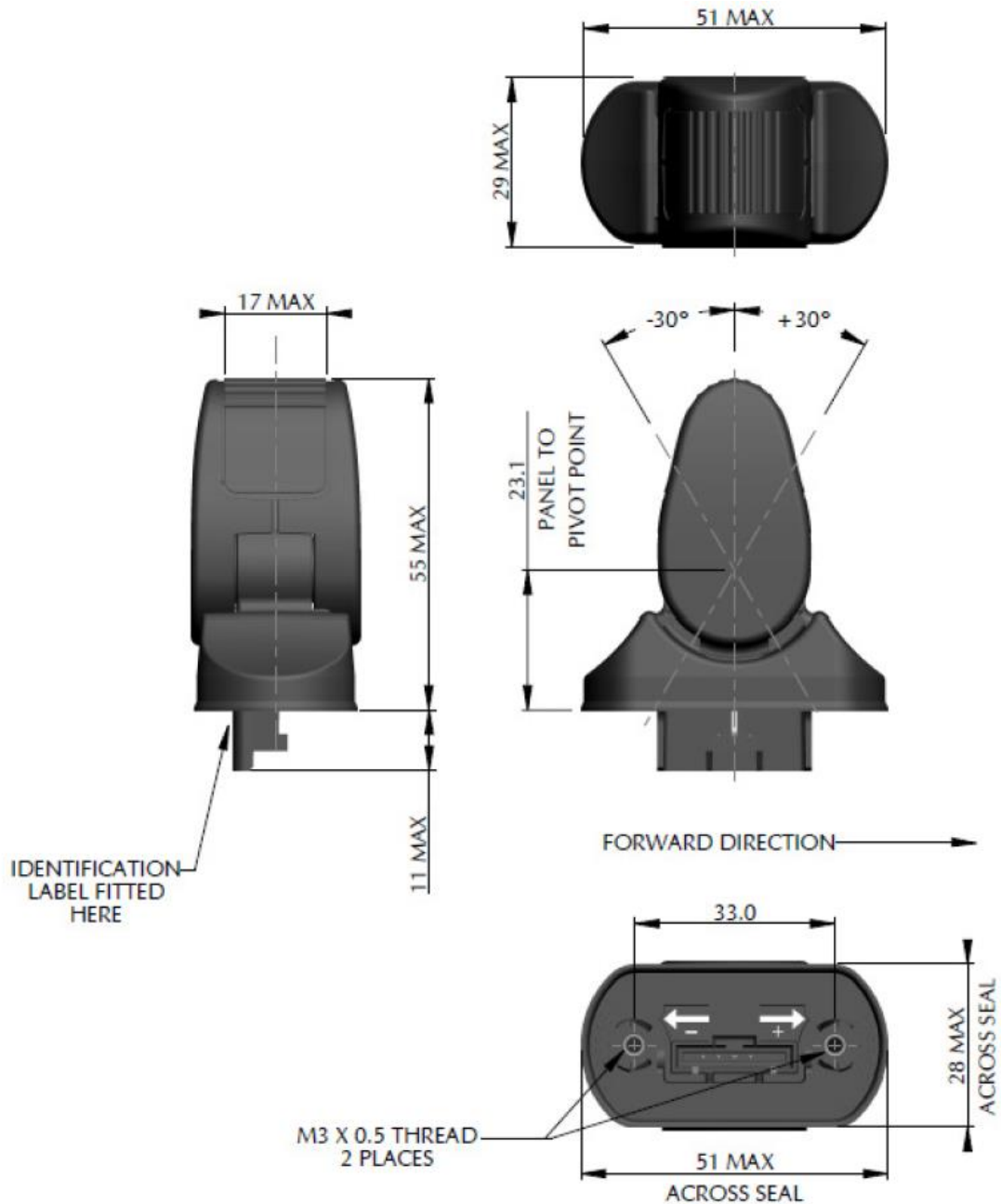

MINIMUM PANEL THICKNESS

See the sealing note

THREAD ENGAGEMENT

6mm ± 1mm

MAXIMUM SCREW TIGHTENING TORQUE

0.75Nm to 0.9Nm



Dimensions - Spring Return to End

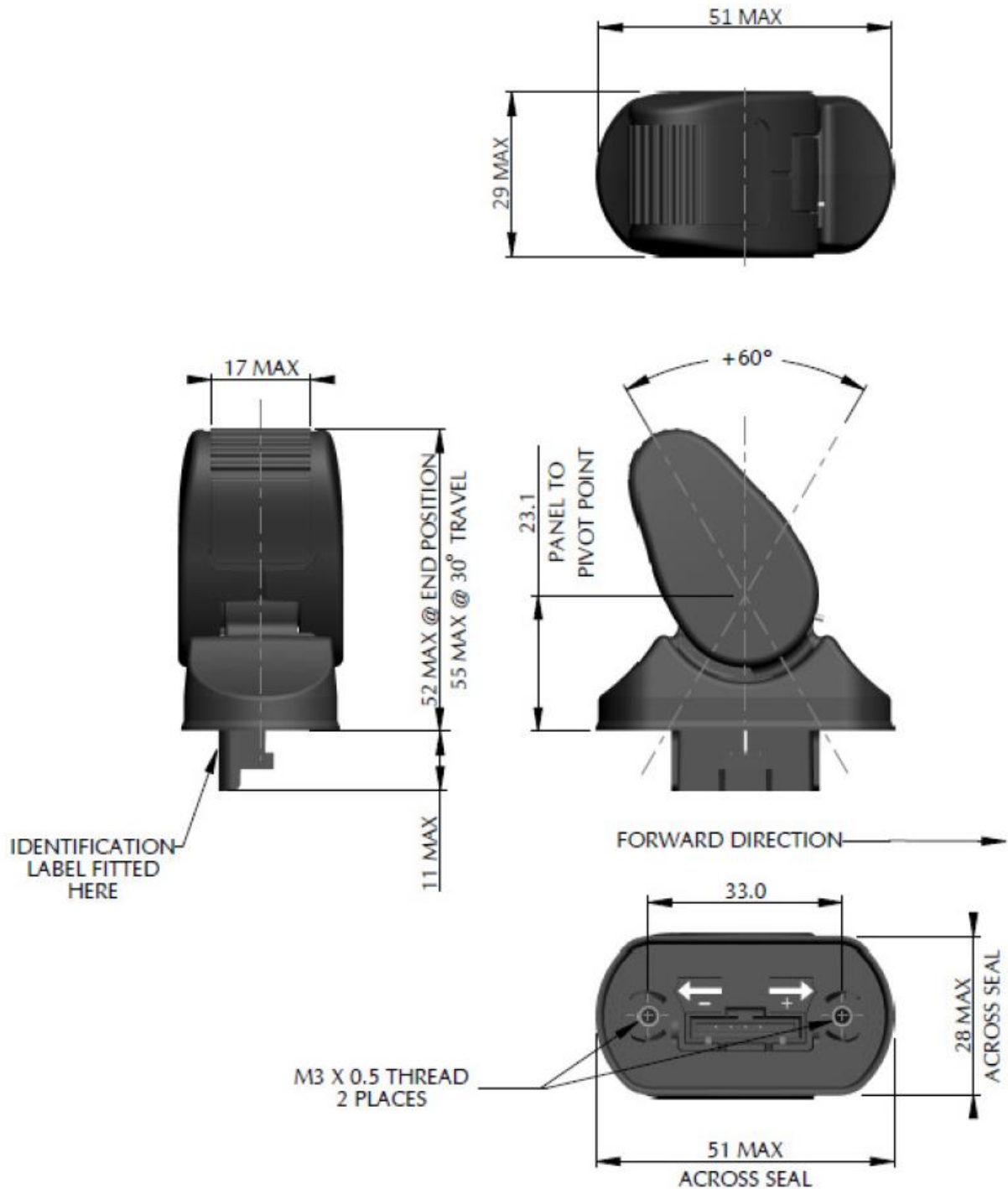

MINIMUM PANEL THICKNESS	See the sealing note
THREAD ENGAGEMENT	6mm ± 1mm
SCREW TIGHTENING TORQUE RANGE	0.5 to 0.65Nm

Panel Mounting Details - Standard

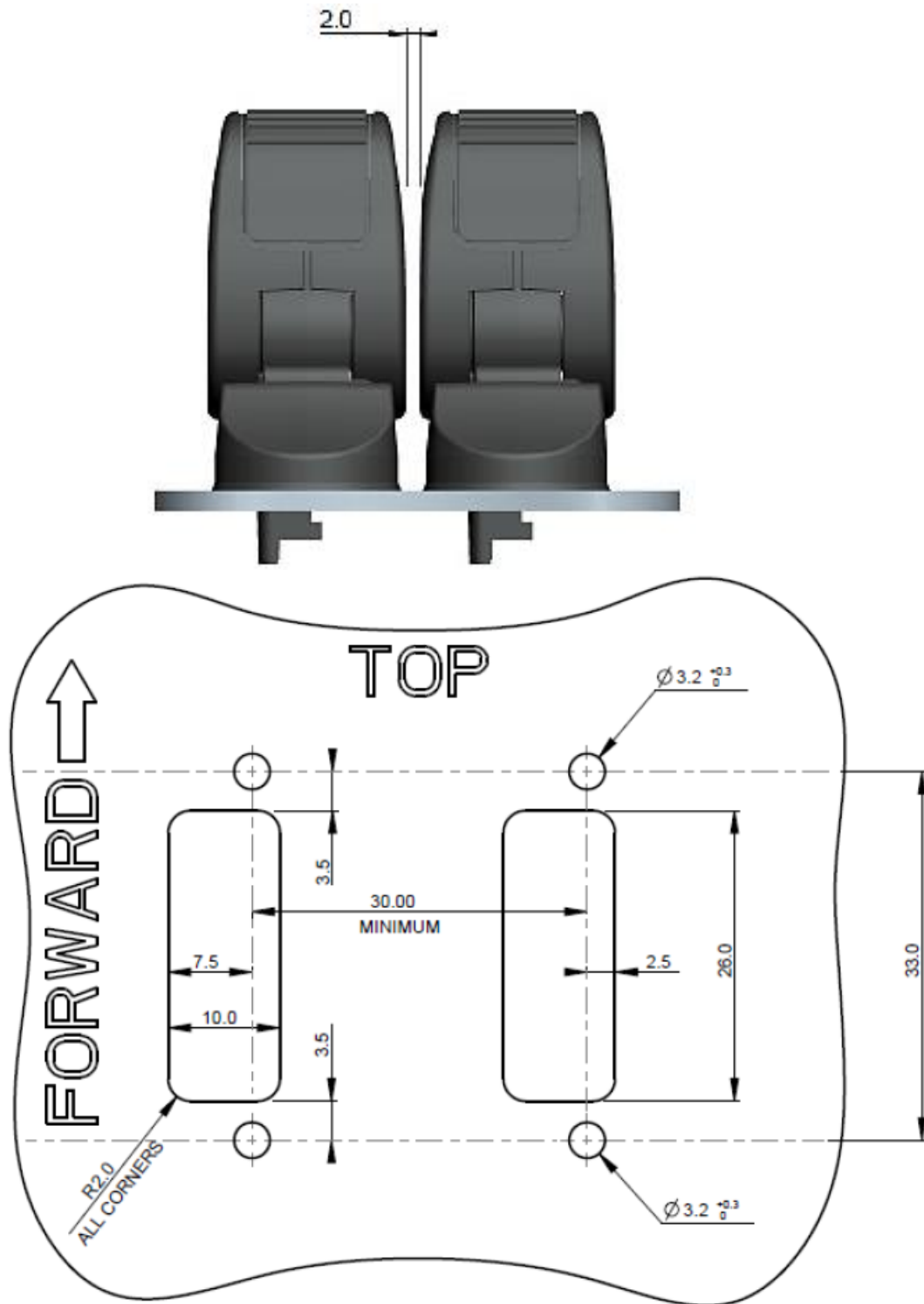

Minimum joystick separation is 2mm





Panel Mounting Details - Non-Standard

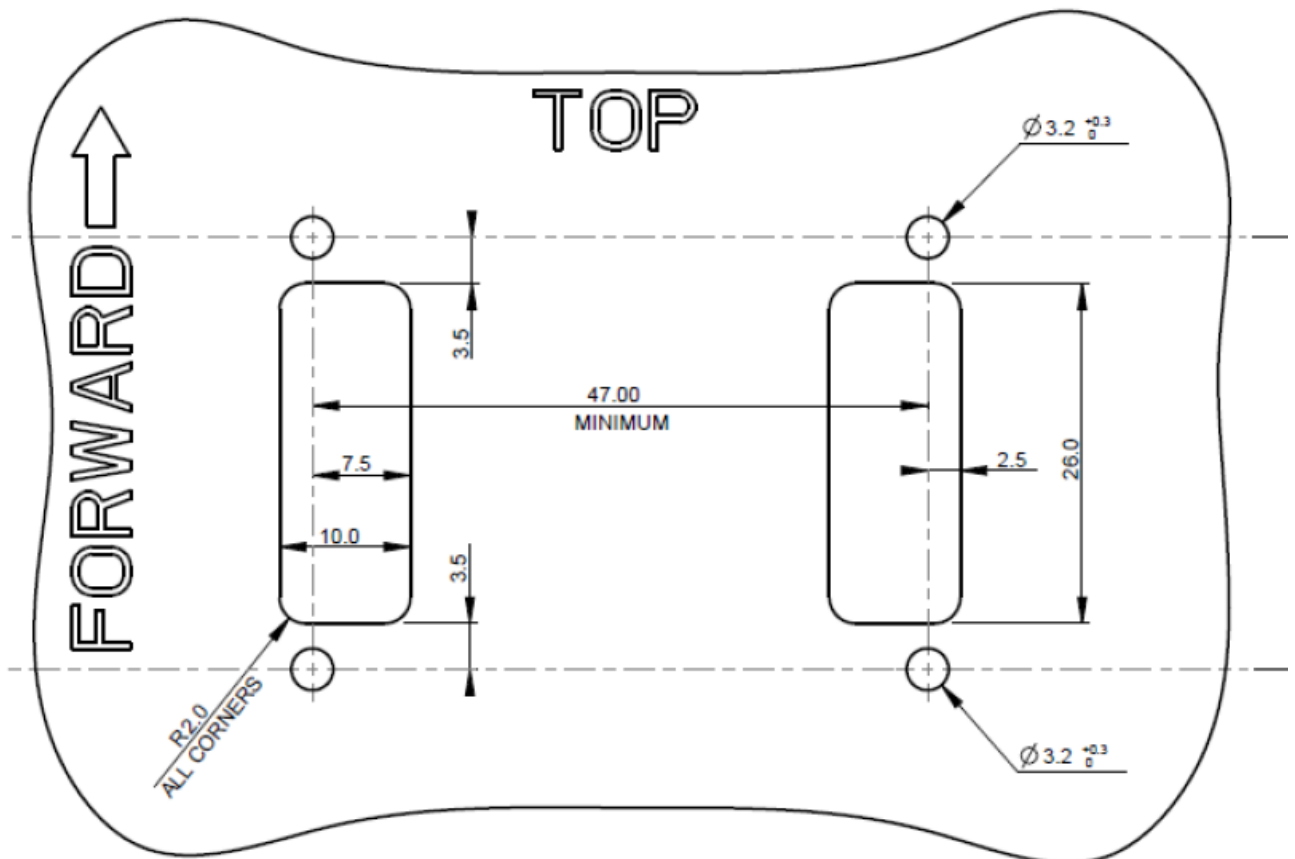
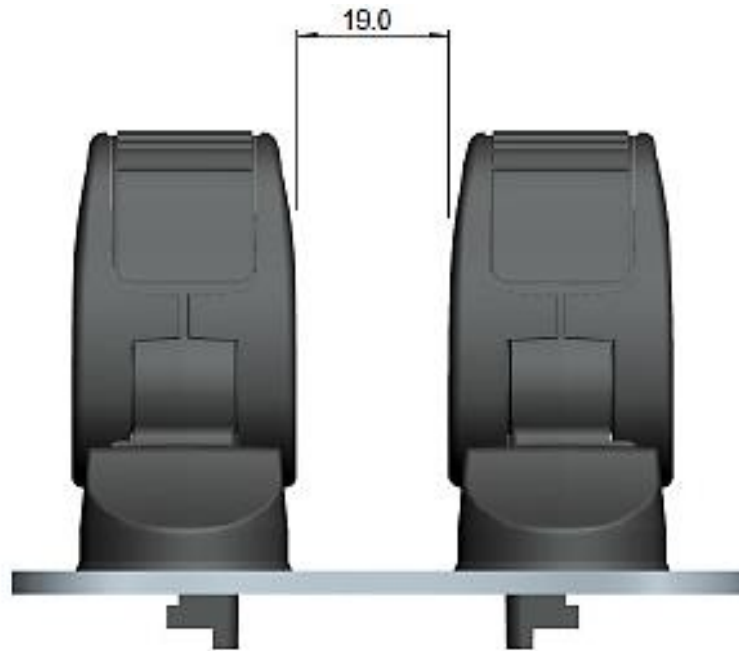

Minimum joystick separation is 19mm

## ELECTRICAL CONNECTIONS

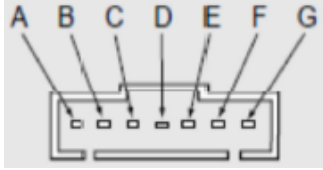

Molex 70553-0006 7-pin connector with gold-plated pins

Recommended mating connector either:

Molex 70400 14-56-2074 (connector and pin kit)

or Molex 70066 50-57-9407 connector body plus 7 pins to the Molex number 70058 16-02-0082.

**Note:** the mating connector must be fitted with gold-plated pins to ensure stable output from the joystick

Standard Cables with a connector fitted are available from Curtiss Wright as follows:

CW part number SA301649 – cable length 500 mm

CW part number SA308599 – cable length 1,000 mm

Pin	Function
A	Not connected
B	5V supply
C	Output 1
D	0V supply
E	Output 2
F	Not connected
G	Not connected



## SPECIFICATIONS

### ELECTRICAL

---

SUPPLY VOLTAGE	5Vdc $\pm$ 0.5Vdc
SUPPLY CURRENT	$\leq$ 25mA (12.5mA max. per channel)
OVER-VOLTAGE PROTECTION	Up to 10Vdc (-40°C to 80°C)
SHORT-CIRCUIT PROTECTION TO GND	Yes
SHORT-CIRCUIT PROTECTION TO SUPPLY	Yes
REVERSE POLARITY PROTECTION	10Vdc continuous
POWER-ON SETTLEMENT	< 1s
RESOLUTION	12-bit (0.025% of measurement range)
NON-LINEARITY	$\pm$ 0.4%
TEMPERATURE COEFFICIENT	$\leq$ 30ppm/°C
TRACKING ERROR	$\pm$ 2%
OUTPUT CLAMPING	Yes (1% above and below the Maximum and Minimum end voltage values) <b>Note:</b> Clamping limits still apply to output voltage after life
OUTPUT TYPE	Dual analogue ratiometric (crossed or parallel)
OUTPUT RANGE: AS SUPPLIED	10-90% $\pm$ 2% of supply voltage (0.5-4.5V nominal) – see after life note below 20-80% $\pm$ 2% of supply voltage (1.0-4.0V nominal) – see after life note below
CENTER VOLTAGE: AS SUPPLIED	48% to 52% of supply voltage – see after life note below
TOLERANCE OF OUTPUT VOLTAGE AT ENDS OF TRAVEL AND CENTER POSITION AFTER LIFE	After 5 million cycles: $\pm$ 3%

### MECHANICAL

---

MECHANICAL LIFE	> 5 million cycles at 3Hz (cycle is center to one end, to other end and back to center)	
MECHANICAL ANGLE	$\pm$ 30° $\pm$ 1° (return to center) 60° $\pm$ 2° (return to end)	
BREAKOUT FORCE AT JOYSTICK TIP	1.0N	
OPERATIVE FORCE AT END OF TRAVEL AT JOYSTICK TIP	3.5N	
MAXIMUM FORCE ON JOYSTICK TIP	50N in-line, 50N transverse	
WEIGHT	$\leq$ 40g	
VIBRATION - SINUSOIDAL	EN 60068-2-6: 2008	1 hour in X, Y and Z axes, 10Hz and 200Hz at 3gn
VIBRATION - SHOCK	EN 60068-2-27: 2008	50g, 6ms, Half Sine, 3 shocks in each of 6 directions
VIBRATION - RANDOM	EN 60068-2-64: 2008	3.6GN, 10-200HZ, 2 hours per axis
BUMP TEST	EN 60068-2-29: 2008	25G, 10MS, 500 Bumps in each of 6 directions
FREE FALL DROP TEST	EN 60068-2-31: 1993	1.0m at Level C, 1.2m at level E

---



**EMC**

RADIATED EMISSIONS	EN 61000-6-4: 2011	30MHz to 1GHz
IMMUNITY	EN 61000-4-3: 2002	100V/M, 80MHz to 1GHz and 1.4GHz to 2.7GHz
CONDUCTED DISTURBANCE IMMUNITY	EN 61000-4-6: 2009	150kHz to 80MHz, 3Vrms, 80%AM, 1kHz sine
ESD	EN 61000-4-2 level 2: 1995	4KV contact (including connector pins) , 4KV Air
POWER FIELD IMMUNITY	EN 61000-4-8 level 4: 1993	30A/m, 50Hz and 60Hz

**ENVIRONMENTAL**

OPERATING TEMPERATURE	-40°C to 85°C	Temperature cycle per EN 60068-2-14: 1999 Thermal shock to EN 60068-2-14: 1999 Temperature and humidity to EN 60068-2-38: 2009
STORAGE TEMPERATURE	-40°C to 85°C	Cold test to EN 60068-2-1: 1993 Dry heat to EN 60068-2-2: 1993
WATER AND DUST INGRESS	IP67 above panel  IP55 below panel, including connector	Panel sealing performance is dependant on the stiffness and surface condition of the panel i.e. free of scratches. It is the responsibility of the customer to define the panel material and thickness to achieve the seal rating
SALT SPRAY	EN 60068-2-11: 1999	

**IMPORTANT INFORMATION**

Whilst Curtiss-Wright Industrial Group - Penny & Giles has designed this joystick to meet a range of applications it is the responsibility of the customer to ensure it meets their specific requirement.

Penny & Giles Controls Ltd makes no warranty or representation in respect of product fitness or suitability for any particular design application, environment, or otherwise, except as may subsequently be agreed in contract for the sale and purchase of products. Customers should therefore satisfy themselves of the actual performance requirements and subsequently the product's suitability for any particular design application and the environment in which the product is to be used.

Continual research and development may require change to products and specification without prior notification.

All trademarks acknowledged.