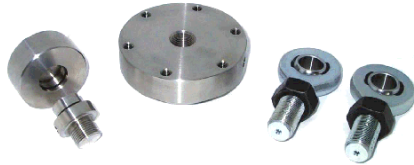

Accessori Accessories

Load	Display	Ris.
0.5 t	0.5000 t	0.1 kg
1 t	1.000 t	1 kg
2.5 t	2.500 t	1 kg
5 t	5.000 t	1 kg
10 t	10.000 t	1 kg
20 t	20.000 t	1 kg
30 t	30.00 t	10 kg
50 t	50.00 t	10 kg
75 t	75.00 t	10 kg
100 t	100.00 t	10 kg

A

RoHS
COMPLIANCE

 $\leq \pm 0.05\%$

 Accuratezza
Accuracy

 Certificato SIT a richiesta
SIT certificate on request

 Dinamometro a basso profilo
Low profile Dynamometer

 Alta stabilità a lungo termine
Long term high stability

 Interamente saldata al LASER
Completely LASER welded

Dimensioni Dimensions

[mm]

CODE	LOAD	ØA	B	C	ØD	ØE	F	G	n°G	H
CDCVTC4100500K	0.5 t	100	86	35	72	32	M20X1.5	9	6	139
CDCVTC41001T5M	1 t									
CDCVTC41002T5M	2.5 t									
CDCVTC41275T5M	5 t	127	110	35	92	47	M30X2	10.5	8	166
CDCVTC412710T5M	10 t									
CDCVTC416520T5M	20 t	165	138	50	108	62	M42X3	17	12	204
CDCVTC416530T5M	30 t			60						
CDCVTC416550T5M	50 t			60						
CDCVTC423075T5M	75 t	230	185	80	145	98	M60X3	26	12	269
CDCVTC4230100T5M	100 t									

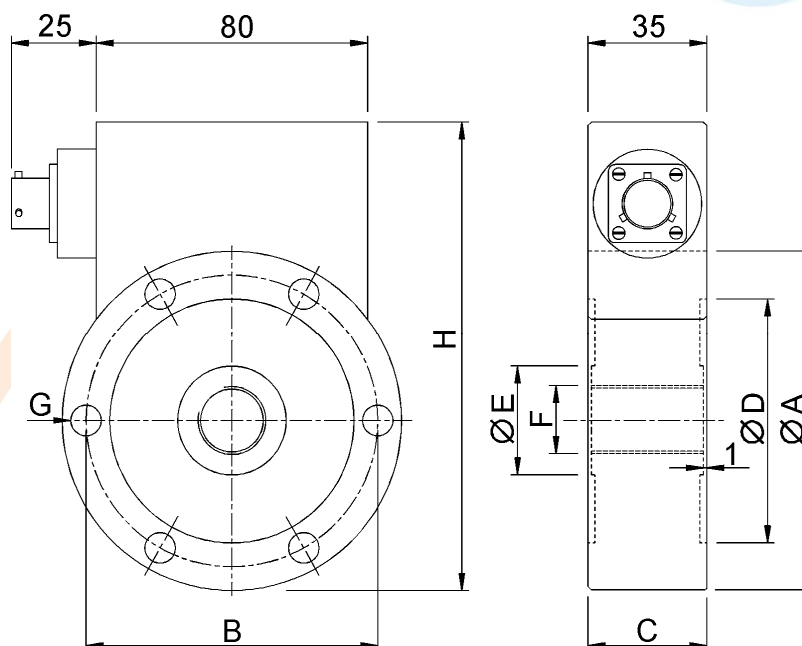

Dati Tecnici	Technical Data					
Accuratezza	Accuracy	≤ ± 0.05% F.S.				
CARICO NOMINALE	NOMINAL LOAD	0.5-1-2.5 t	5-10 t	20-30 t	50 t	75-100 t
LINEARITA'	LINEARITY	≤ ±0.05% F.S.				
ISTERESI	HYSTERESIS	≤ ±0.05% F.S.				
RIPETIBILITA'	REPEATABILITY	≤ ±0.02% F.S.				
RISOLUZIONE INTERNA	INTERNAL RESOLUTION	±99999 div.				
CONVERSIONI AL SECONDO (filtro 0)	READINGS PER SEC. (0 filter)	100 (10ms)				
TEMPERATURA DI RIFERIMENTO	REFERENCE TEMPERATURE	+23°C				
CAMPO NOMINALE DI TEMPERATURA	TEMPERATURE NOMINAL RANGE	-10/+40 °C				
TEMPERATURA DI ESERCIZIO	SERVICE TEMPERATURE	-10/+70 °C				
TEMPERATURA DI STOCCAGGIO	STORAGE TEMPERATURE	-20/+80 °C				
EFFETTO DELLA TEMPERATURA 10°C	TEMPERATURE EFFECT (10°C)					
a) sullo zero	a) on zero	≤ ±0.028% F.S.				
b) sulla sensibilità	b) on sensitivity	≤ ±0.024% F.S.				
EFFETTO CARICO TRASVERSALE:	EFFECT OF TRANSVERSE LOAD:					
a) al 10% del carico nominale	a) at 10% of nominal load	≤ ±0.030% F.S.				
FUNZIONE DI ZERO	ZERO FUNCTION	100% F.S.				
FILTRO DIGITALE PROGRAMMABILE	PROGRAMMABLE DIGITAL FILTER	0÷5				
RISOLUZIONE PROGRAMMABILE	FILTER PROGRAMMABLE RESOLUTION	1, 2, 5, 10, 20, 50, 100				
FUNZIONE DI PICCO	PEAK FUNCTION	Pos. (+), Neg. (-) or Disabled				
DISPLAY ROSSI (alta efficienza)	RED DISPLAY (high efficiency)	7 segments				
ALTEZZA DISPLAY	DISPLAY HEIGHT	13 mm				
ALIMENTAZIONE DI RIFERIMENTO	RECOMMENDED POWER SUPPLY	10÷15Vdc				
ALIMENTAZIONE MASSIMA	ABSOLUTE POWER SUPPLY	18Vdc overvoltage and overcurrent protected				
ASSORBIMENTO MAX	MAX. ELECTRICAL INPUT	50mA				
CONNETTORE DI ALIMENTAZIONE	POWER CONNECTOR	MIL PT02E10-6P				
VALORI MECCANICI LIMITE RIFERITI AL CARICO NOMINALE :	MECHANICAL LIMIT VALUES REFERRED TO NOMINAL LOAD :					
a) carico di servizio	a) service load	120%				
b) carico limite	b) max permissible load	150%				
c) carico di rottura	c) breaking load	>300%				
d) massimo carico trasversale	d) max transverse load	50%				
e) carico dinamico limite	e) max permissible dynamic load	75% ⁽¹⁾				
FRECCIA MAX. AL CARICO NOMINALE	DISPLACEMENT AT NOMINAL LOAD	-0.06mm	-0.09mm	-0.17mm	-0.17mm	-0.23mm
PESO	WEIGHT	-1.60 kg	-2.45 kg	-5.80 kg	-6.80 kg	-16.5 kg
CLASSE DI PROTEZIONE (EN 60529)	PROTECTION CLASS (EN 60529)	IP40				
MATERIALE DINAMOMETRO	EXECUTION MATERIAL	Acciaio Inox / Stainless Steel				
LUNGHEZZA CAVO	CABLE LENGTH	5m				
VITI DI FISSAGGIO:	FIXING SCREWS					
a) diametro	a) diameter	M8	M10	M16	M16	M24
b) classe di resistenza	b) resistance class	12.9	12.9	12.9	12.9	12.9
c) coppia di serraggio	c) tightening torque	40 Nm	70 Nm	368 Nm	368 Nm	460 Nm

Test e calibrazioni eseguite in **COMPRESSIONE** con il dinamometro montato al supporto e viti di fissaggio correttamente serrate.

Tests and calibrations performed in **COMPRESSION** with the dynamometer mounted on a bearing support with correctly tightened clamping screws.

⁽¹⁾ Il carico dinamico deve essere applicato al filetto centrale del dinamometro e non sulla corona esterna di fissaggio.

The dynamic load must be applied to the dynamometer central thread and not to the external fixing rim.

Opzioni Options

USCITA SERIALE	SERIAL OUTPUT	RS232C
BAUD RATE PROGRAMMABILE	PROGRAMMABLE BAUD RATE	38400, 19200, 9600, 4800

Collegamenti Elettrici Electrical Connections

MIL6M	INPUT	CABLE (optional)	CAVO (opzione)
A	POWER + (12Vdc)	Red	Rosso
B	POWER - (GND)	Black	Nero
C	GND	Blue	Blu
D	RX	Yellow	Giallo
E	TX	White	Bianco
F	EARTH ⁽¹⁾ 	Shield	Schermo

⁽¹⁾ Collegato al corpo del dinamometro. / Connected to the body of the dynamometer.

Applicazioni Applications

Per l'applicazione del dinamometro vedere il data sheet: **TC4.211** / For the dynamometer application look at the data sheet: **TC4.211**