

A58HM

PHOTOELECTRIC ROTARY ENCODER

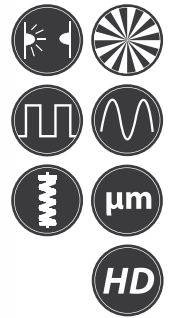

The encoder A58HM is used to measure angular position of the key machine components, industrial robots, comparators, rotary tables, servo drives and to establish an informational link with DCC, NC or Digital Readout Units. The encoder has integrated stator coupling so it can be fixed directly onto object shaft. Mounting adapter - similar to adapter of encoder A58H - is available on request.

The encoder is used in automatic control, on-line gauging, process monitoring systems, etc.

The housing of the encoder is fixed to an object by

means of four screws M3 or through adapter.

The fixation to object shaft is made by two screws M3.

Three versions of output signals are available:

- A58HM-A - sinusoidal signals, with amplitude approx. 11 μ A_{pp};
- A58HM-AV - sinusoidal signals, with amplitude approx. 1 V_{pp};
- A58HM-F - square-wave signals (TTL or HTL) with integrated subdividing electronics for interpolation x1, x2, x3, x4, x5, x8, x10.

MECHANICAL DATA

Line number on disc (z)	100; 250; 500; 600; 800; 1000; 1024; 1125; 1250; 1500; 2000; 2048; 2500; 3000; 3600; 4000; 5000; 9000; 10800
Pulse number per shaft revolution for A58-F	Z x k, where k=1,2,3,4,5,8,10 (k - interpolation factor)
Maximum shaft speed	10000 rpm
Permissible motion of shaft:	± 0.03 mm
- axial	0.05 mm
- radial (at shaft end)	
Accuracy (T ₁ -period of lines on disc in arc. sec)	$\pm 0.1T_1$, arc. sec
- on option for z < 5000	$\pm 0.05T_1$, arc. sec
- on option for z > 5000	± 12.0 arc. sec

Starting torque at 20°C	≤ 0.025 Nm
Rotor moment of inertia	$< 1.5 \times 10^{-4}$ kgm ²
Protection (housing) (IEC 529)	IP64
Protection (shaft side) (IEC 529)	IP64
Maximum weight without cable	0.35 kg
Operating temperature	0...+70 °C
Storage temperature	-30...+80 °C
Maximum humidity (non-condensing)	98 %
Permissible vibration (55 to 2000 Hz)	≤ 100 m/s ²
Permissible shock (11 ms)	≤ 300 m/s ²

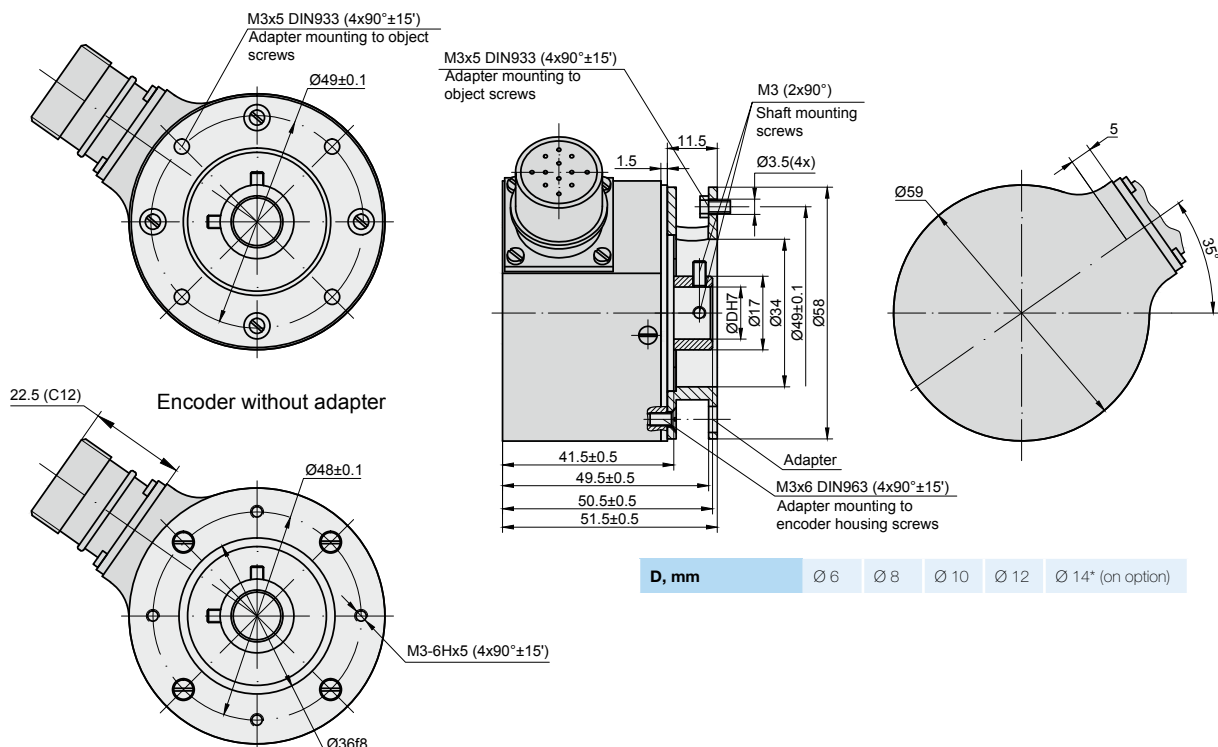

ELECTRICAL DATA

VERSION	A58HM-A $\sim 11 \mu\text{App}$	A58HM-AV $\sim 1 \text{Vpp}$	A58HM-F \square TTL; \square HTL
Supply voltage (U_p)	+5 V \pm 5%	+5 V \pm 5%	+5 V \pm 5%; +(10 to 30) V
Max. supply current (without load)	80 mA	120 mA	120 mA
Light source	LED	LED	LED
Incremental signals	Two sinusoidal I_1 and I_2 Amplitude at 1 k Ω load: - $I_1 = 7\text{-}16 \mu\text{A}$ - $I_2 = 7\text{-}16 \mu\text{A}$	Differential sine +A/-A and +B/-B Amplitude at 120 Ω load: - A = 0.6-1.2 V - B = 0.6-1.2 V	Differential square-wave $U1/\overline{U1}$ and $U2/\overline{U2}$. Signal levels at 20 mA load current: - low (logic "0") ≤ 0.5 V at $U_p=+5$ V - low (logic "0") ≤ 1.5 V at $U_p=10$ to 30 V - high (logic "1") ≥ 2.4 V at $U_p=+5$ V - high (logic "1") $\geq (U_p-2)$ V at $U_p=10$ to 30 V
Reference signal	One quasi-triangular I_0 peak per revolution. Signal magnitude at 1 k Ω load: - $I_0 = 2\text{-}8 \mu\text{A}$ (usable component)	One quasi-triangular +R and its complementary -R per revolution. Signals magnitude at 120 Ω load - R = 0.2-0.8 V (usable component)	One differential square-wave $U0/\overline{U0}$ per revolution. Signal levels at 20 mA load current: - low (logic "0") < 0.5 V at $U_p=+5$ V - low (logic "0") < 1.5 V at $U_p=10$ to 30 V - high (logic "1") > 2.4 V at $U_p=+5$ V - high (logic "1") $> (U_p-2)$ V at $U_p=10$ to 30 V
Maximum operating frequency	(-3 dB) ≥ 160 kHz	(-3 dB) ≥ 180 kHz	(160 x k) kHz, k-interpolation factor
Direction of signals	I_2 lags I_1 for clockwise rotation	B lags A for clockwise rotation	$U2$ lags $U1$ with clockwise rotation
Maximum rise and fall time	-	-	< 0.5 μs
Standard cable length	1 m, without connector	1 m, without connector	1 m, without connector
Maximum cable length	5 m	25 m	25 m
Output signals			

Note:

- Maximum working rotation speed (with proper encoder counting) is limited by maximum operating frequency and maximum mechanical rotation speed.
- If cable extension is used, power supply conductor cross-section should not be smaller than 0.5 mm².

MOUNTING DIMENSIONS

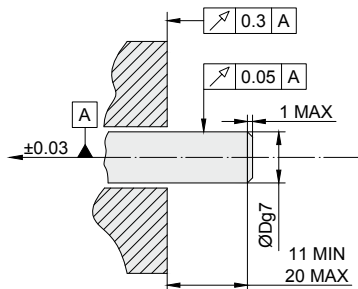

ADAPTER

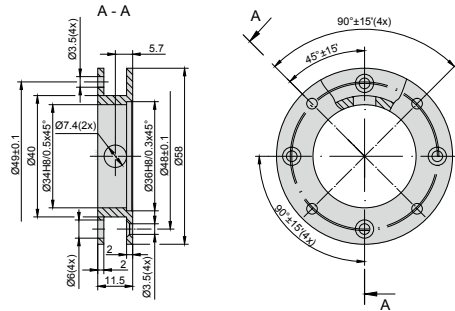

ACCESSORIES

CONNECTORS FOR CABLE	C9 9-pin round connector	C12 12-pin round connector	RS10 10-pin round connector	ONC 10-pin round connector
DIGITAL READOUT DEVICES	CS3000		CS5000	
EXTERNAL INTERPOLATOR	NK			

ORDER FORM

A58HM - XX - XXXX/XXXX - XX - XX - XXX - X

OUTPUT SIGNAL VERSION:	PULSE NUMBER PER REVOLUTION:	OPTIONAL LINE NUMBER ON DISC (Z):	SHAFT HOLE DIAMETER:	SUPPLY VOLTAGE:	CONNECTOR TYPE:	ADAPTER:
A AV F	1...100 ... 1...108000	100 ... 10800 *only for A58HM-F	6, 8, 10, 12, 14*, mm *with additional hub for shaft mounting	05V - +5V 30V - +(10...30)V* * only for A58HM-F with HTL output signals	C9 - round, 9 pins C12 - round, 12 pins RS10 - round, 10 pins ONC - round, 10 pins	W - without adapter S - with adapter

ORDER EXAMPLES:

- A58HM-AV-1024-6-05V-C12-W
- A58HM-F-4000-8-30V-C12-S
- A58HM-F-4000/500-8-30V-C12-S