

CMT

MAGNETIC LINEAR ENCODER

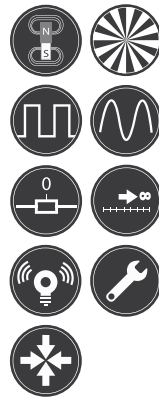

Non contact magnetic linear encoder CMT has measuring length up to 50 m.

The encoder is used to convert linear displacements of key machine components into electrical signals containing information about the value and direction of the displacement.

The encoder is intended to use in particular heavy conditions. It is protected against products of technological processes and mechanical actions.

Encoder consists of metal based magnetic band MP, reading head and profile rail PS with protective band. The length of magnetic band could be up to 50 m.

Encoder could be supplied with external zero signal actuator (magnet), which allows usage one of many reference marks made on magnetic band. Zero signal actuator is not necessary if the magnetic band with reference marks made according customer requirements (MP200Z) is used. The reading head has LED, which indicates the reference mark passage by head.

Two versions of output signals are available:

- CMT - Square-wave signals, with integrated subdividing electronics for interpolation.
- CMT - Sinusoidal signals, with amplitude approx. 1 Vpp, which require external subdividing electronics.

MECHANICAL DATA

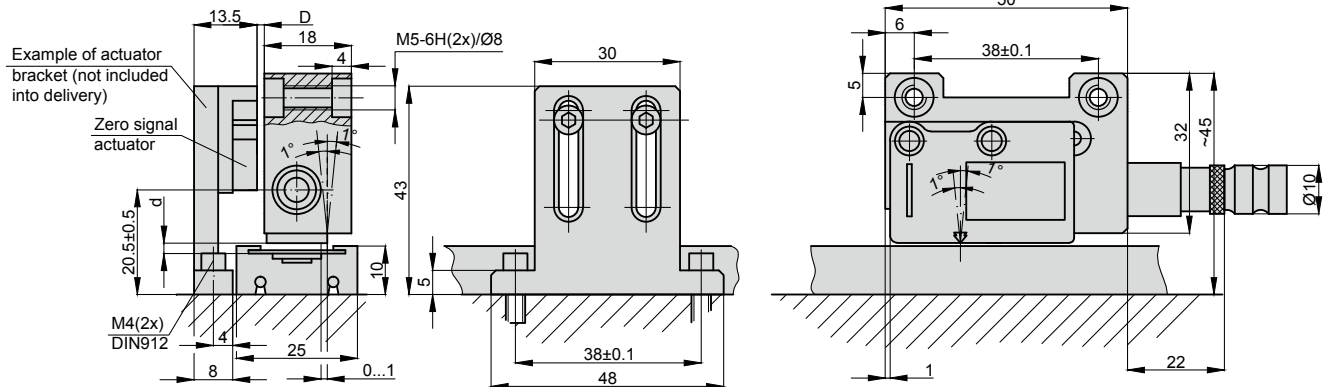

Gap "d" between magnetic tape (protective) cover and reading head:

- for CMTM- $d = 0.3 \dots 0.7$ mm;
- for CMTH - $d = 0.3 \dots 2.2$ mm;
- for CMTP - $d = 0.1 \dots 0.3$ mm

Warning: To get the best accuracy distance d must be the lowest possible (in the indicated range).

	D(MM)	
	1.5	2.5
CMTP (MP100)	Not available	Not available
CMTM (MP200)	1.5 nom.	2.5 MAX
CMTH (MP500)	1 nom.	2 MAX

CMT-F PARAMETERS

Measuring length (ML)	up to 50 m (20 m with MP500)
Repeatability	± 1 increment
Max. measuring frequency	300 kHz
Power supply	(5 ... 28) DC ±5%, V
Current consumption without load	60 mA max.
Current consumption with load	140 max. (with 5V and R=120Ω); 115 max (with 12V and R=1.2kΩ) ; 90 max (with 28V and R=1.2kΩ), mA
Phase shift between signals	90° ±5°
Protection (IEC 529)	IP67
Operating temperature	0...+50 °C
Storage temperature	-20...+80 °C
Permissible humidity	100% non-condensing
Permissible vibration (55...2000 Hz)	300 m/s ²
Permissible shock (11 ms)	1000 m/s ²
Output signal shape	Square-wave TTL pulses
Output signals	6 - two main + one zero signal and their complementary
Output scheme	Line driver (TTL optional)
Weight of reading head	40 g
Standard cable length	2.0 m
Max. cable length of head	10.0 m
Max. cable length of encoder (2 m of head + adapter)	100.0 m
Electrical protections	From inversion of power supply polarity; from short circuit on output port

READING HEAD MODIFICATIONS

READING HEAD	CMTP-F	CMTM-F	CMTH-F
Reference (zero) signal *	Constant pitch every 1 mm (version C)	Constant pitch every 2 mm (version C) With external actuator (version E) Reference marks made on magnetic band according customer requirements (version Z)	Constant pitch every 5 mm (version C) With external actuator (version E) Reference marks made on magnetic band according customer requirements (version Z)
Pole pitch	1+1 mm	2+2 mm	5+5 mm
Accuracy **	±10 µm	±15 µm	±40 µm
Resolution (after x4 in CNC)	0,5; 1; 5; 10 µm	1; 5; 10; 25; 50; 100; 500; 1000 µm	1; 5; 10; 25; 50; 100 µm
Max. traversing speed	0.6 (CMTP-F05); 1,2 (CMTP-F10) m/s	1.2 (CMTM-F10); 12 (CMTM-F100) m/s	6 (CMTH-F50); 12 (CMTH-F100) m/s

*Version C - without reference signal

Version E - zero signal is generated when external zero actuator acts to reference mark, which is made on magnetic band.

It is possible to use several actuators.

Version Z - zero signal is generated when reference mark is acted by actuator incorporated into reading head

**The smaller is the gap between reading head and magnetic band the better is accuracy of encoder.

CMT - AV

Measuring length (ML)	up to 50 m (20 m with MP500)
Repeatability	±1 increment
Max. measuring frequency	300 kHz
Power supply	(5 ... 28) DC ±5%, V
Current consumption without load	60 mA max.
Current consumption with load	140 max. (with 5V and R=120Ω); 115 max (with 12V and R=1,2kΩ) 90 max (with 28V and R=1,2kΩ) mA
Phase shift between signals	90° ±5°
Protection (IEC 529)	IP67
Operating temperature	0...+50 °C
Storage temperature	20...+80 °C
Permissible humidity	100% non-condensing
Permissible vibration (10...2000 Hz)	300 m/s ²
Permissible shock (11 ms)	1000 m/s ²
Output signal shape	Sine-wave
Output signals	Two main + one zero (square-wave pulse)
Output scheme	Line driver; TTL
Weight of reading head	100 g
Standard cable length	2.0 m
Max. cable length of head	10.0 m
Max. cable length of encoder (2 m of head + adapter)	100.0 m

READING HEAD MODIFICATIONS

READING HEAD	CMTP-AV	CMTM-AV	CMTH-AV
Reference (zero) signal	Constant pitch every 1 mm (version C)	Constant pitch every 2 mm (version C) With external actuator (version E)	Constant pitch every 5 mm (version C) With external actuator (version E)
Pole pitch	1+1 mm	2+2 mm	5+5 mm
Accuracy	±10 μm	±15 μm	±40 μm
Resolution (depending on external interpolator)	up to 0,1 μm	up to 0,5 μm	up to 1 μm
Max. measuring frequency	12 kHz	6 kHz	2.4 kHz

MAGNETIC BAND

Accuracy (at 20°C)	±30 (standard); ±15 (optional) μm/m
Width	10 mm
Thickness	1.3 mm
Length	50 m max. (20 m max.- for MP 500)
Thermal expansion coefficient	10,5 x 10 ⁻⁶ °C ⁻¹ (at 20°C±0,1°C)
Bend radius	80mm min.
Weight of magnetic band	65 g/m
Weight of protective cover	25 g/m
Operating temperature,	0...+70 °C
Storage temperature	-20...+80 °C

Note: In order to ensure the accuracy of encoder magnetic band must be longer than ML by 80 mm (40 mm from each side)

PROFILE RAIL PS

Length of one module (standard)	1 m
Length	1 ... 50 m (pitch 1 m)
Width and height	25x10 mm
Material	aluminium

Profile rail PS with protective band SB is used for support of magnetic band with width 10 mm. Profile rail is easy mounted and has not adhesive joints. The lengths of more than 1 m are obtained by joining together several rail modules.

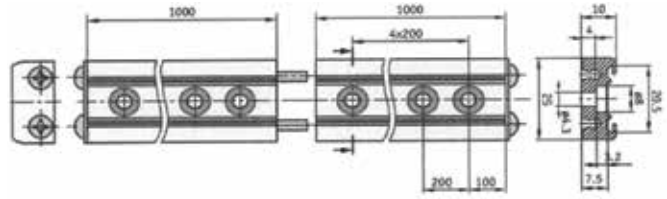

PROTECTIVE BAND SB

Length (standard)	1 m
Length	profile rail + 36 mm
Adhesive tape	not required with PS
Material	stainless steel

MAGNETIC BAND MODIFICATIONS

MAGNETIC BAND	MP100	MP200/MP200Z	MP500/MP500Z
Pole pitch	1+1 mm	2+2 mm	5+5 mm
Reference mark position	-	on request from left or right at pitches of 4 mm or multiples	on request from left or right at pitches of 10 mm or multiples
	<i>Note: With MP100 magnetic band, it is not possible to use any protective cover (CV or SP)</i>	<i>Note: Magnetic band MP200Z is used only with reading head MTMxxxZ</i>	<i>Note: Magnetic band MP500Z is used only with reading head MTXxxxZ</i>

COLOR OF CABLE WIRES AND OUTPUT SIGNALS

	CMT-F		CMT-AV			
Green	U1		A		A and B amplitude 0,6 V...1,2 V (~ 1V)	
White	U2		B		R amplitude 0,25...0,6V (useful part)	
Red	(5...28)V		(5...28)V		A and B phase shift 90° ±10° el.	
Blue	0V		0V		Reference voltage U0 2,5 V	
Brown	U0		R		Amplitudes of signals are referred to measurement made with 120 Ω impedance and power supply voltage of reading head 5V±5%.	
Orange	U1		A			
Light-blue	U2		B			
Yellow	U0		R			
Shield	Shield		Shield		Shield	

ACCESSORIES

CONNECTORS FOR CABLE	B12 12-pin round connector	C12 12-pin round connector	D9 9-pin flat connector	D15 15-pin flat connector	RS10 10-pin round connector	ONC 10-pin round connector
DIGITAL READOUT DEVICES	CS3000			CS5000		

ORDER FORM

CMT	X - XXXX - X - XX / XX - XX / XX - X - XX / XXX							
READING HEAD VERSION:	OUTPUT SIGNALS AND RESOLUTION:	REFERENCE MARKS:	MAGNETIC BAND:	PROTECTIVE STEEL COVER:	OR ALUMINIUM PROTECTIVE SUPPORT:	EXTERNAL REFERENCE MARK ACTUATOR SME:	CABLE LENGTH:	CONNECTOR TYPE:
P - CMTM M - CMTM H - CMTH	AV - sine wave F05 - 0,5µm F10 - 1µm F50 - 5µm F100 - 10µm F250 - 25µm F500 - 50µm F1000 - 100µm F5000 - 500µm F10000 - 1000µm	C - standard, without reference mark; E - with external reference mark actuator; Z/L - made on magnetic band by order at any place. L - distance in mm from begin of ML	MP100/01 - 1m ... MP200/01 - 1m ... MP200Z/01 - 1m ... MP500/01 - 1m ... (20m max for MP500)	W - without CV/01 - 1m CV/02 - 2m CV/03 - 3m ...	W - without PS PS/01 - 1m PS/02 - 2m PS/03 - 3m ...	0 - without SME 1 - with SME	01 - 1m 02 - 2m 03 - 3m ...	W - without connector B12 - round, 12 pins C12 - round, 12 pins D9 - flat, 9 pins D15 - flat, 15 pins RS10 - round, 10 pins ONC - round, 10 pins

ORDER EXAMPLE: 1) CMTH-F50-C-MP100/01-0-02/W