



These adapters provide a commonly accepted industry method of attaching fixtures to load cells and test frames. They prevent grip rotation and allow for quick removal and installation.

Several thread sizes and variations are available to suit most common test frames, load cells, grips, and force gauges. Eye ends and adapters are available individually or as kits.

◀ Eye ends and adapters are shown with Mark-10 wedge grips, test stand, and force gauge

Load Cell / Test Frame Configuration

Force Gauge Configuration

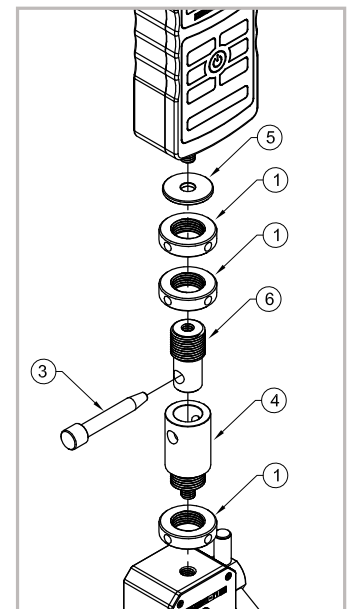
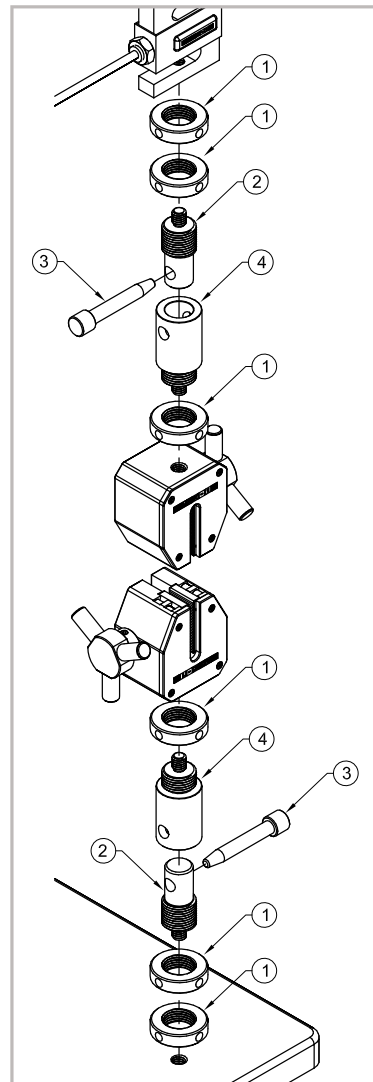

Base / Load Cell Adapter Kits

AC1047	AC1047-1	AC1047-2	AC1047-3	Item No.	Part No.	Qty.
X				2	G1081	1
	X			2	G1081-1	1
		X		2	G1081-2	1
			X	2	G1081-3	1
X	X	X		3	G1080	1
X	X	X		1	G1079	2

Grip Adapter Kits

AC1046	AC1046-1	AC1046-2	Item No.	Part No.	Qty.
X			4	G1083	1
	X		4	G1083-1	1
		X	4	G1083-2	1
X	X	X	1	G1079	1

Force Gauge Adapter Kits

AC1045	AC1045-1	AC1045-2	Item No.	Part No.	Qty.
X			6	G1082	1
		X	2	G1081-2	1
	X		6	G1082-1	1
X			5	G1084	1
	X		5	G1084-1	1
X	X	X	1	G1079	2
X	X	X	3	G1080	1
		X	5	G1084-2	1

Item No.	Part No.	Description
1	G1079	Lock ring, 3/4-16
2	G1081	Eye end, #10-32M
	G1081-1	Eye end, 5/16-18M
	G1018-2	Eye end, 1/2-20M
	G1081-3	Eye end, 1/4-28M
3	G1080	Anchor pin
4	G1083	Eye end adapter, #10-32M
	G1083-1	Eye end adapter, 5/16-18M
	G1083-2	Eye end adapter, 1/2-20M
5	G1084	Washer, 0.20 ID
	G1084-1	Washer, 0.32 ID
	G1084-2	Washer, 0.51 ID
6	G1082	Eye end, #10-32F
	G1082-1	Eye end, 5/16-18F
Not shown	G1088	Spanner wrench (see next page)



Specifications subject to change without prior notice



Distribué par Wimesure

54, rue de Versailles • 78460 CHEVREUSE • Tél. 01 30 47 22 00 • Fax 01 30 47 28 29
www.wimesure.fr • info@wimesure.fr

G1084-X Jam Washers

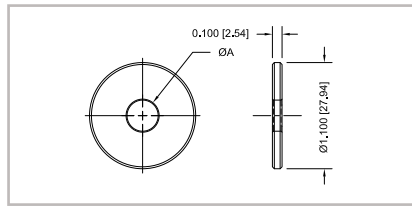

Part No.	ØA	Weight lb [kg]
G1084	0.20 [5.1]	0.03 [0.01]
G1084-1	0.32 [8.2]	0.03 [0.01]
G1084-2	0.51 [12.9]	0.03 [0.01]

G1079 Lock Ring

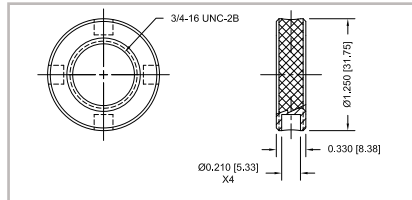

Weight lb [kg]
0.07 [0.03]

G1081-X Eye Ends

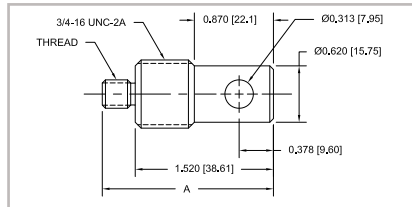

Part No.	A	Thread	Weight lb [kg]	Capacity lbF [N]
G1081	1.82 [46.2]	#10-32	0.13 [0.06]	200 [1,000]
G1081-3	1.87 [47.5]	1/4-28	0.13 [0.06]	200 [1,000]
G1081-1	1.88 [47.8]	5/16-18	0.14 [0.06]	500 [2,500]
G1081-2	2.02 [51.3]	1/2-20	0.15 [0.07]	2,000 [10,000]

G1082-X Eye Ends

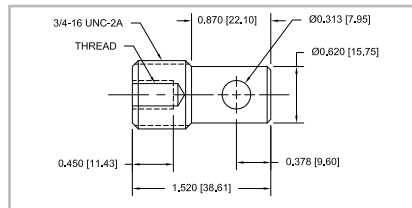

Part No.	Thread	Weight lb [kg]	Capacity lbF [N]
G1082	#10-32	0.13 [0.06]	200 [1,000]
G1082-1	5/16-18	0.14 [0.05]	500 [2,500]

G1083-X Eye Ends

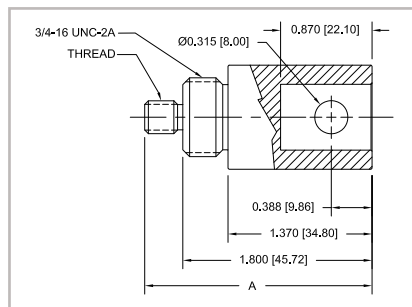

Part No.	A	Thread	Weight lb [kg]	Capacity lbF [N]
G1083	2.10 [53.3]	#10-32	0.26 [0.12]	200 [1,000]
G1083-1	2.16 [54.9]	5/16-18	0.26 [0.12]	500 [2,500]
G1083-2	2.30 [58.4]	1/2-20	0.28 [0.13]	2,000 [10,000]

G1080 Anchor Pin

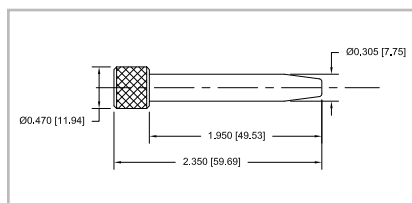

Weight lb [kg]
0.06 [0.03]

G1088 Spanner Wrench



MARK-10



Distribué par Wimesure

54, rue de Versailles • 78460 CHEVREUSE • Tél. 01 30 47 22 00 • Fax 01 30 47 28 29
www.wimesure.fr • info@wimesure.fr



Specifications subject to change without prior notice