

# F900 Series

## Air Velocity and Air Temperature Sensors

### Features

- Measures air & inert gas velocity and temperature
- Standard flow ranges between 0.15-10 m/s (approximately 30-2000 fpm)
- Temperature measurements from 0-70°C
- Digital UART Interface
- Linear 0-4 VDC airflow output from 0 to full-scale
- Wide voltage supply: 7-13VDC
- Temperature-compensated from 15-35°C
- Ideal for ducted or open airflow applications
- Available in multiple sensor heads
- Wide acceptance angle ( $\pm 30^\circ$ )



### About the F900

The F900 Airflow Sensor is designed to measure the velocity and temperature of airflows in applications such as HVAC, industrial processes, automotive, air filtration systems, electronics enclosures, and critical containment areas such as biological safety cabinets, fume hoods, and clean rooms.

With standard airflow sensing ranges from 0.15-2 m/s (30-400 fpm) to 0.15-10 m/s (30-2000 fpm), depending on the setting, the Series F900 offers unparalleled price to performance, compact size, reliability and resistance to mechanical shock and vibration.

The F900 series has a linear 0-4V output or a digital TTL output depending on the model. The F900 is easy to install and operate. An adjustable mounting bracket is included with the sensor. In addition, the F900 can be ordered with any of the AccuSense remote sensing head options.

F900 Sensor Head Options

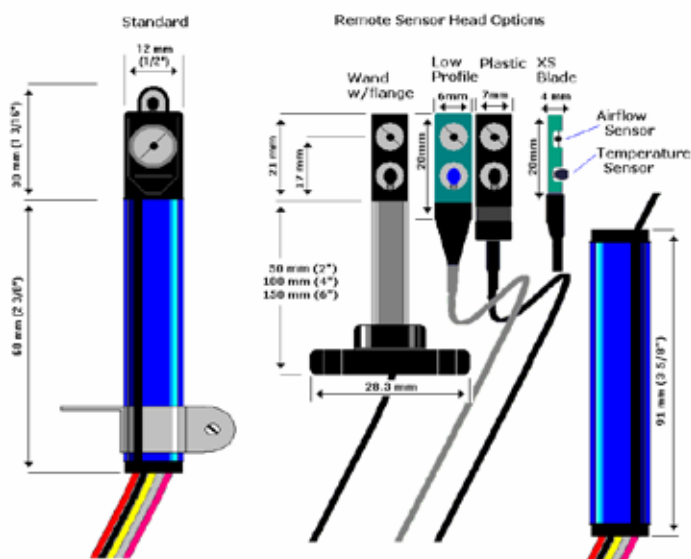

Block Diagram of F900

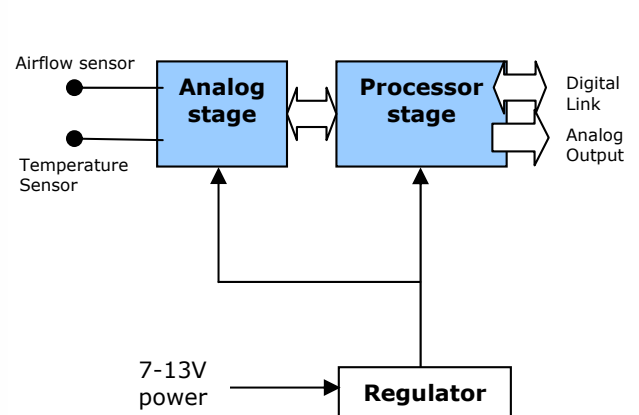

## Airflow Measurement

Standard medium is air at standard pressure (101.3 kPa, 29.95" Hg). For altitude compensation and use with other gases, please contact DegreeC.

0.15 - 2 m/s (30 - 394 fpm)  
 0.15 - 5 m/s (30 - 985 fpm)  
 0.15 - 10 m/s (30 - 1969 fpm)

### Available Airflow Accuracies

15 - 35°C Greater of  $\pm 10\%$  of reading or  $\pm 0.05$  m/s (10 fpm) or  $\pm 1\%$  of full-scale

15 - 35°C Greater of  $\pm 5\%$  of reading or  $\pm 0.05$  m/s (10 fpm) or  $\pm 1\%$  of full-scale

Output resolution: 4,000 steps.

Repeatability:  $\pm 1\%$  under same conditions

## Temperature Measurement

Range 0 - 70°C (50 - 140°F)	Available on TTL output only
Accuracy $\pm 1^\circ\text{C}$ above 1 m/s (196 fpm) $\pm 1.5^\circ\text{C}$ below 1 m/s (196 fpm)	Resolution is $\pm 0.1^\circ\text{C}$

## Electrical Specifications

Supply Voltage 7-13 VDC	Warm-up Time <5 seconds
Supply Current 40-75 mA	Operating Temperature 0 - 70°C (32-158°F)
Response Time 1.5 seconds	Storage Temperature -10 to 100°C
Output is linear 0-4 VDC full scale for calibrated range, up to 4.9V beyond calibrated range (airflow only) or TTL level RS-232 (both airflow & temperature).	

## Mechanical Specifications

Dimensions	100 mm long X 12 mm diameter for standard unit, 91 mm X 12 mm for long tube with remote sensor heads
Vibration	Up to 25 G's
Acceptance Angles	Standard, rod w/flange, plastic heads are $\pm 30^\circ$ , low-profile is $\pm 45^\circ$ , XS blade is $\pm 60^\circ$ from perpendicular

## Connection Specifications

Pin 1 Black	Supply Return
Pin 2 Red	Supply 7-13 VDC
Pin 3 White	Analog Airflow Output (0-4Vout) for calibrated range, up to 4.9V beyond calibrated range.
Pin 4 Orange	Digital serial output - 19200 BPS, RS232 protocol, TTL level, 8 bit, 1 stop bit - RXD
Pin 5 Yellow	Digital serial input - 19200 BPS, RS232 protocol, TTL levels, 8 bit, 1 stop bit - TXD
Connector	Molex#22-01-2057 or equivalent

## Part Number Format

F900 - V - A - B - S - L

### V = Velocity Range

N = 0.15 - 2 m/s  
 O = 0.15 - 5 m/s  
 P = 0.15 - 10 m/s

### A = Accuracy Specification

5 = Greater of 5% of reading or  $\pm 0.05$  m/s or 1% full-scale  
 10 = Greater of 10% of reading or  $\pm 0.05$  m/s or 1% full-scale

### B = Body Type

0 = Standard (Default) -short tube  
 1 = Long tube  
 (for remote sensor heads)

### S = Sensor Head Type (for B = 1 ONLY)

0 = Plastic  
 1 = Low Profile  
 2 = 50 mm (2") SS wand /w flange  
 4 = 100 mm (4") SS wand /w flange  
 6 = 150mm (6") SS wand /w flange  
 9 = XS Blade

### L = Sensor Cable Length (for B = 1 ONLY)

2 = 2 m

User Manual available at [www.degreeC.com](http://www.degreeC.com)